

Ref.	Spare Description	Quantity	Code
1	display board	1	66404761
2	fan motor	1	66401601
3	inlet valve	1	66400354
4	defrosting valve coil	1	66402301
5	ice full switch	1	66402601
6	condensation sensor	1	66402701
7	PC board	1	66400411
8	electrical metal body	1	75730551
9	electrical box cover	1	75730601

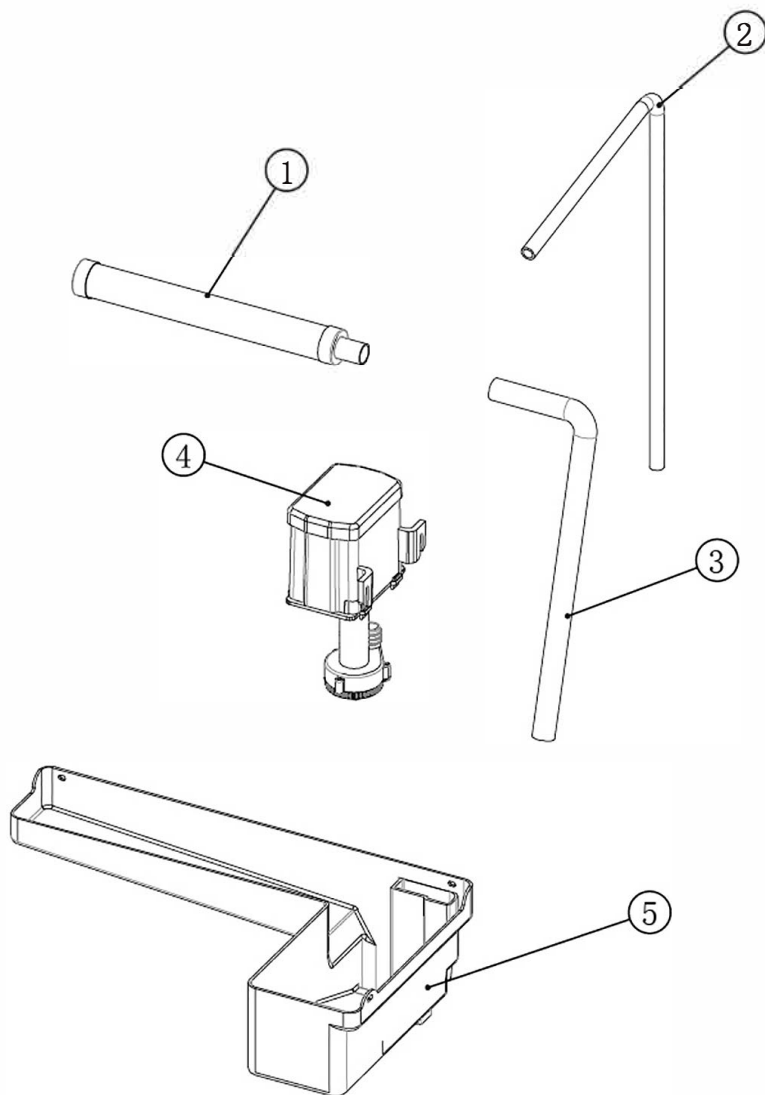

Ref.	Spare Description	Quantity	Code
1	sprinkler tube assembly	1	32480652
2	silicone hose	1	02111111
3	water pipe -80	1	44401156
4	small water pump assembly	1	66401003
5	sinks - 80	1	32400954

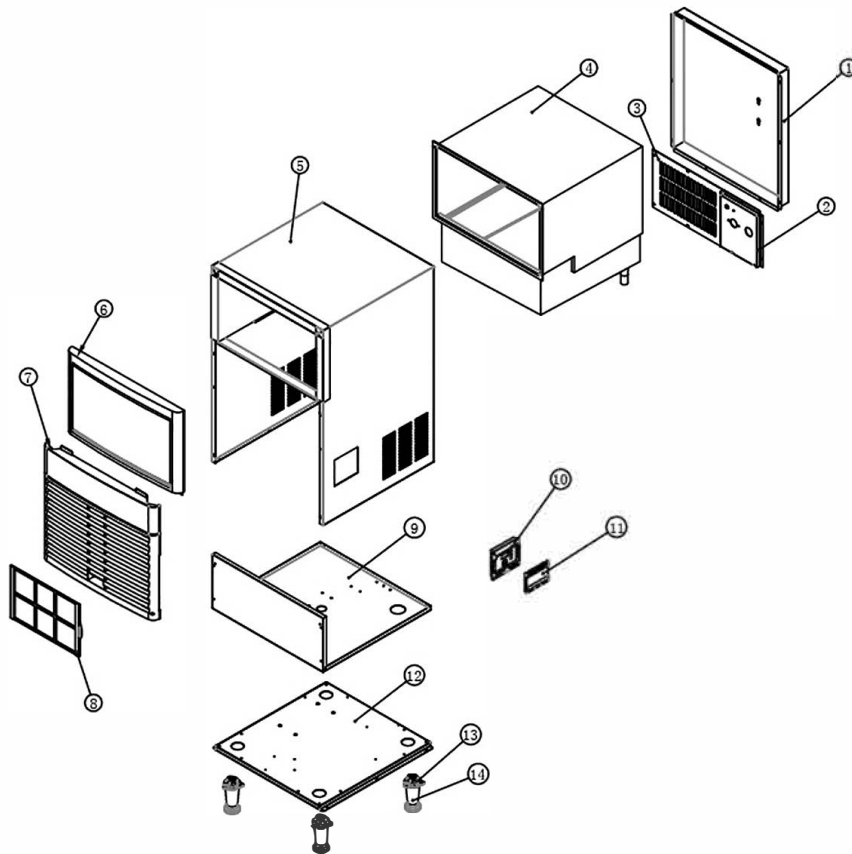

Ref.	Spare Description	Quantity	Code
1	back panel	1	75730351
2	inlet and outlet bracket	1	75730452
3	rear ventilator -80	1	75630401
4	ice machine liner -120	1	32480402
5	cabinets - 120	2	75730252
6	door frame -80	1	32480051
7	front venting window -80	1	32481571
8	venting window filter	1	32402172
9	inner partition -120	1	75630502
10	drawn panel frame -31	1	32480571
11	control panel cover -31	1	32480591
12	bottom plate - 120	1	75630302
13	foot mount	4	32550671
14	foot body	4	32550651

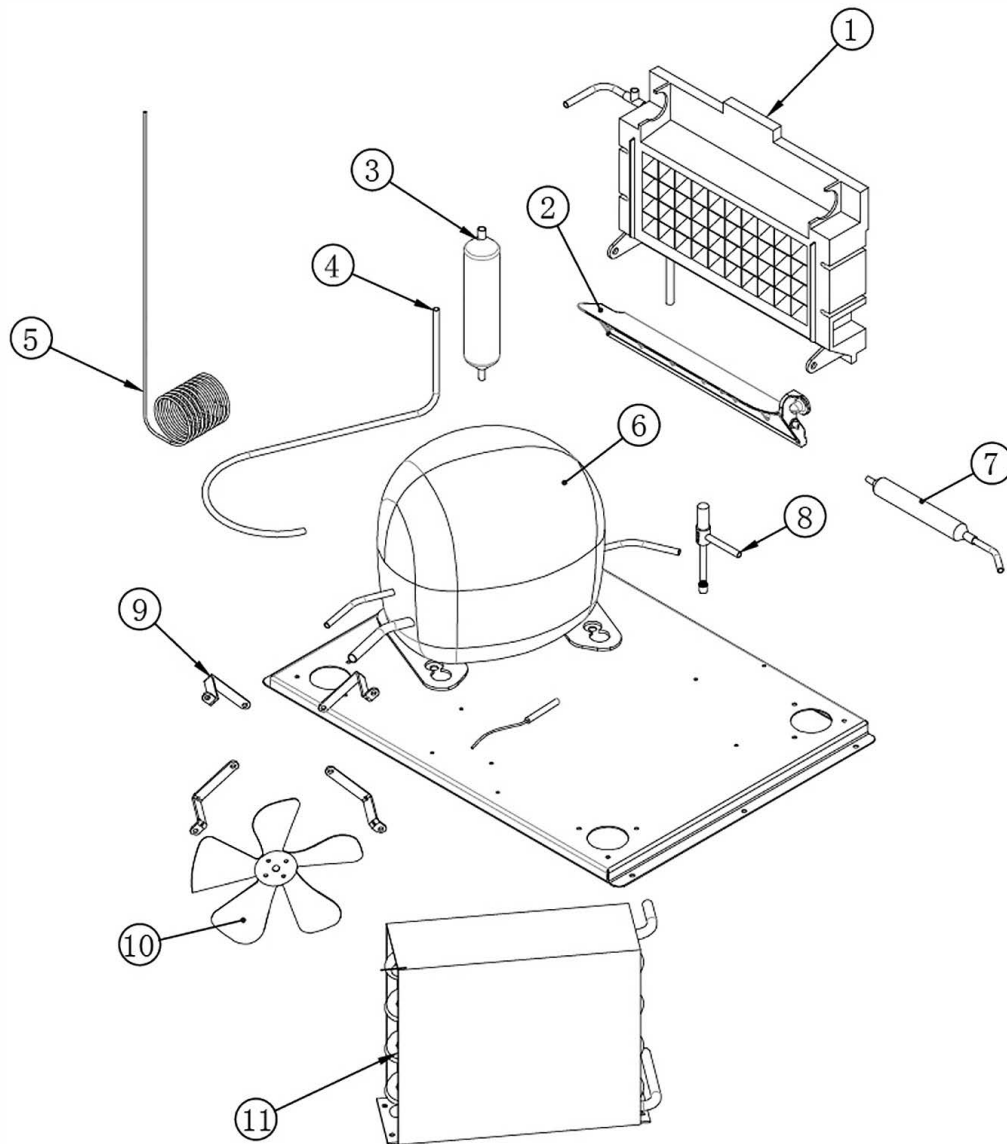

Ref.	Spare Description	Quantity	Code
1	evaporator	1	66400104
2	skating board -120	1	32480502
3	gas-liquid separator -120	1	66401402
4	return air pipe	1	02120103
5	capillary	1	02131003
6	compressor - NF7ML	1	66400059
7	drying filter	1	66401351
8	defrosting valve body	1	66400601
9	fan bracket	4	75732201
10	fan leaves	1	66401707
11	condenser -120	1	66400215